

RC5532/RC5532A

High Performance Dual Low Noise Operational Amplifier

Features

- Small signal bandwidth – 10 MHz
- Output drive capability – 600Ω, 10 VRMS
- Input noise voltage – 5 nV/√Hz
- DC voltage gain – 50,000
- AC voltage gain – 2200 at 10 kHz
- Power bandwidth – 140 kHz
- Slew rate – 8 V/μS
- Large supply voltage range – ±3V to ±20V

Description

The RC5532 is a high performance, dual low noise operational amplifier. Compared to standard dual operational amplifiers, such as the RC747, it shows better noise performance, improved output drive capability, and considerably higher small-signal and power bandwidths.

This makes the device especially suitable for application in high quality and professional audio equipment, instrumentation, control circuits, and telephone channel amplifiers. The op amp is internally compensated for gains equal to one. If very low noise is of prime importance, it is recommended that the RC5532A version be used which has guaranteed noise specifications.

Block Diagram

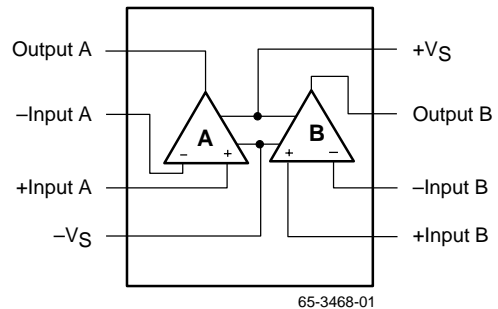

Pin Assignments

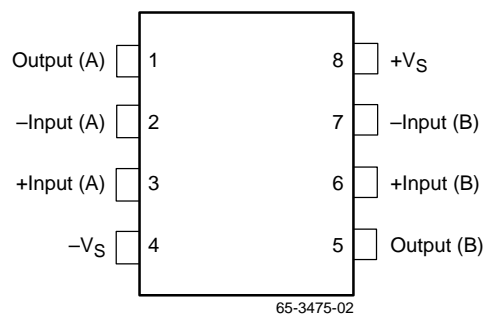
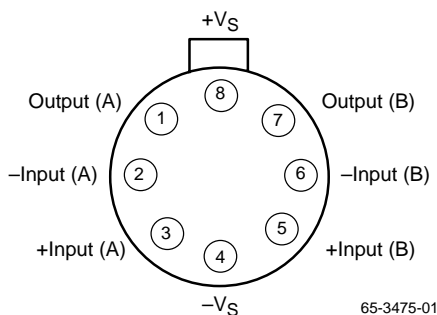

Absolute Maximum Ratings

(beyond which the device may be damaged)¹

Parameter		Min	Typ	Max	Units
Supply Voltage				±22	V
Input Voltage				±VS	V
Differential Input Voltage				0.5	V
P _{DTA} < 50°C	PDIP			468	mW
	CerDIP			833	
	SOIC			658	
Junction Temperature	PDIP			125	°C
	CerDIP, TO-99			175	
Storage Temperature		-65		150	°C
Operating Temperature	RM5532/A	-55		125	°C
	RC5532/A	0		70	
Lead Soldering Temperature (10 sec)				300	°C

Notes:

1. Functional operation under any of these conditions is NOT implied.
2. For supply voltages less than ±15V, the absolute maximum input voltage is equal to the supply voltage.
3. Short circuit to ground on one amplifier only.

Operating Conditions

Parameter			Min	Typ	Max	Units
θ _{JC}	Thermal resistance	CerDIP		45		°C/W
		TO-99		50		
θ _{JA}	Thermal resistance	PDIP		160		°C/W
		CerDIP		150		
		TO-99		190		
For T _A > 50°C Derate at		PDIP		6.25		mW/°C
		CerDIP		8.33		
		TO-99		5.26		

DC Electrical Characteristics

($V_S = \pm 15V$ and $T_A = +25^\circ C$ unless otherwise noted)

Parameters	Test Conditions	RM5532/5532A			RC5532/5532A			Units
		Min	Typ	Max	Min	Typ	Max	
Input Offset Voltage			0.5	2.0		0.5	4.0	mV
	Over Temperature			3.0			5.0	mV
Input Offset Current				100		10	150	nA
	Over Temperature			200			200	nA
Input Bias Current			200	400		200	800	nA
	Over Temperature			700			1000	nA
Supply Current			6.0	11		6.0	16	mA
	Over Temperature			13			22	mA
Input Voltage Range		± 12	± 13		± 12	± 13		V
Common Mode Rejection Ratio		80	100		70	100		dB
Power Supply Rejection Ratio		86	100		80	100		dB
Large Signal Voltage Gain	$R_L \geq 2\text{ k}\Omega$, $V_{OUT} = \pm 10V$	50			25	100		V/mV
	Over Temperature	25			15	50		
	$R_L \geq 600\Omega$, $V_{OUT} = \pm 10V$	40			15	50		
	Over Temperature	20			10			
Output Voltage Swing	$R_L \geq 600\Omega$	± 12	± 13		± 12	± 13		V
	$R_L = 600\Omega$, $V_S = \pm 18V$	± 15	± 16		± 15	± 16		
	$R_L \geq 2\text{ k}\Omega$	± 12	± 13					
Input Resistance (Diff. Mode)			300			300		k Ω
Short Circuit Current			38			38		mA

Notes:

- Diodes protect the inputs against over-voltage. Therefore, unless current-limiting resistors are used, large currents will flow if the differential input voltage exceeds 0.6V. Maximum input current should be limited to $\pm 10\text{mA}$.
- Over Temperature: RM = $55^\circ C \leq T_A \leq 125^\circ C$; RC = $0^\circ C \leq T_A \leq 70^\circ C$

Electrical Characteristics

($V_S = \pm 15V$ and $T_A = +25^\circ C$)

Parameters	Test Conditions	RC/RM5532			RC/RM5532A			Units
		Min	Typ	Max	Min	Typ	Max	
Input Noise Voltage Density	$F_O = 30\text{ Hz}$		8.0			8.0	12	nV/ $\sqrt{\text{Hz}}$
	$F_O = 1\text{ kHz}$		5.0			5.0	6.0	
Input Noise Current Density	$F_O = 30\text{ Hz}$		2.7			2.7		pA/ $\sqrt{\text{Hz}}$
	$F_O = 1\text{ kHz}$		0.7			0.7		
Channel Separation	$F = 1\text{ kHz}$, $R_S = 5\text{ k}\Omega$		110			110		dB

AC Electrical Characteristics

($V_S = \pm 15V$ and $T_A = +25^\circ C$)

Parameters	Test Conditions	Min	Typ	Max	Units
Output Resistance	$A_V = 30$ dB Closed Loop, $F = 10$ kHz, $R_L = 600\Omega$		0.3		Ω
Overshoot	Unity Gain, $V_{IN} = 100$ mV _{p-p} , $C_L = 100$ pF, $R_L = 600\Omega$		10		%
Gain	$F = 10$ kHz		2.2		V/mV
Gain Bandwidth Product	$C_L = 100$ pF, $R_L = 600\Omega$		10		MHz
Slew Rate			8.0		V/ μ S
Power Bandwidth	$V_{OUT} = \pm 10V$		140		kHz
	$V_{OUT} = \pm 14V$, $R_L = 600\Omega$, $V_S = \pm 18V$		100		kHz

Test Circuits

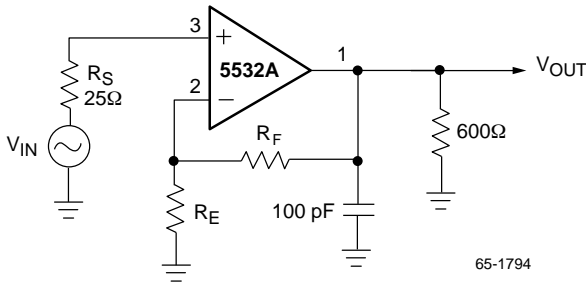

65-1794

Figure 1. Closed Loop Frequency Response

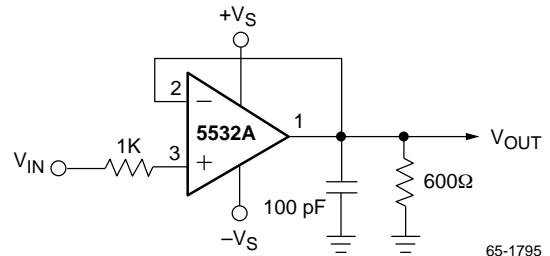

65-1795

Figure 2. Follower, Transient Response

Typical Performance Characteristics

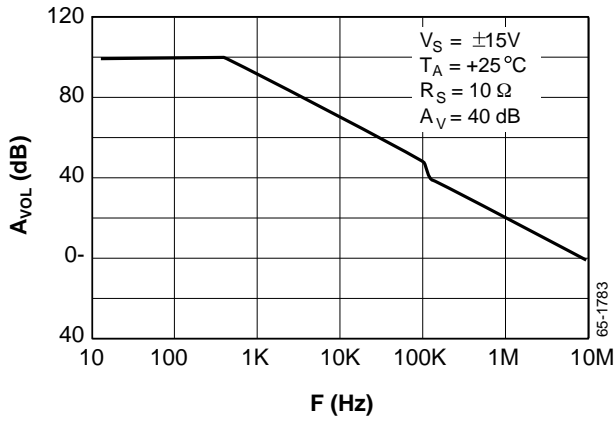

Figure 3. Open Loop Gain vs. Frequency

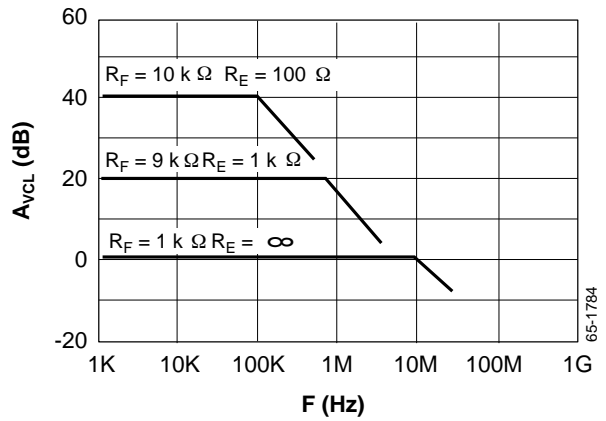

Figure 4. Closed Loop Gain vs. Frequency

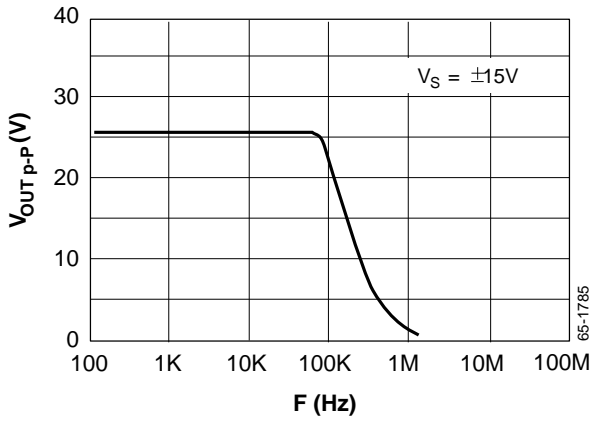

Figure 5. Output Voltage Swing vs. Frequency

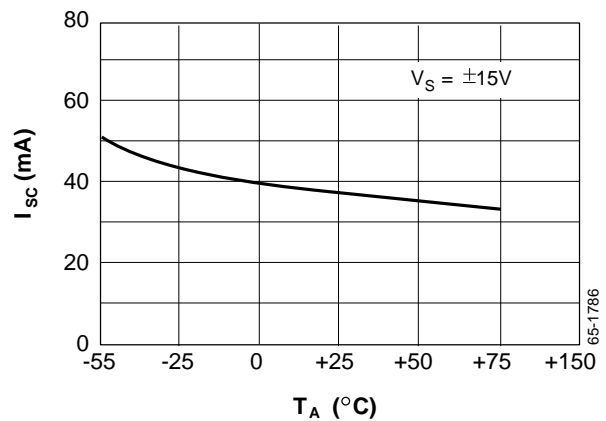

Figure 6. Short Circuit Current vs. Temperature

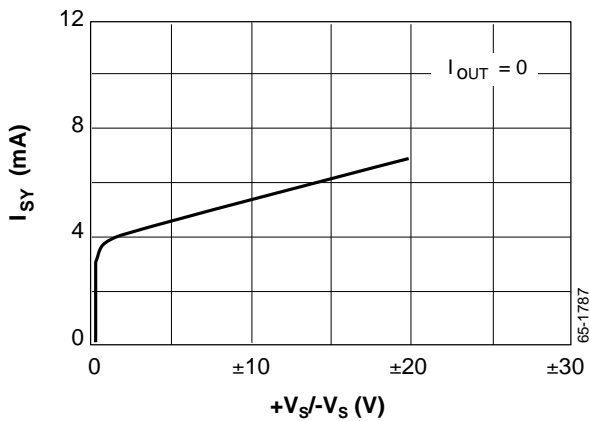

Figure 7. Supply Current vs. Supply Voltage

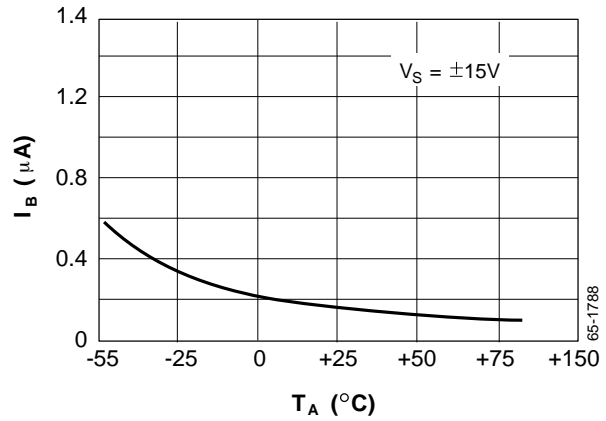

Figure 8. Input Bias Current vs. Temperature

Typical Performance Characteristics (continued)

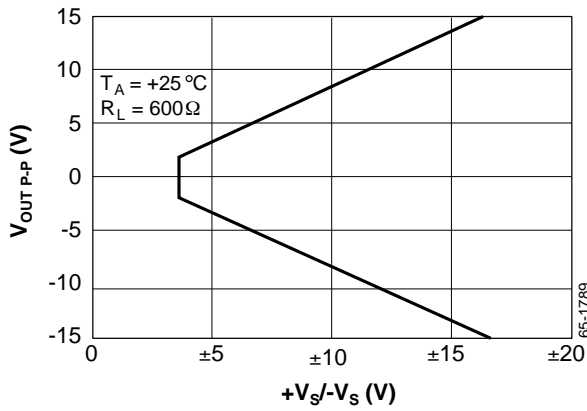

Figure 9. Output Voltage Swing vs. Supply Voltage

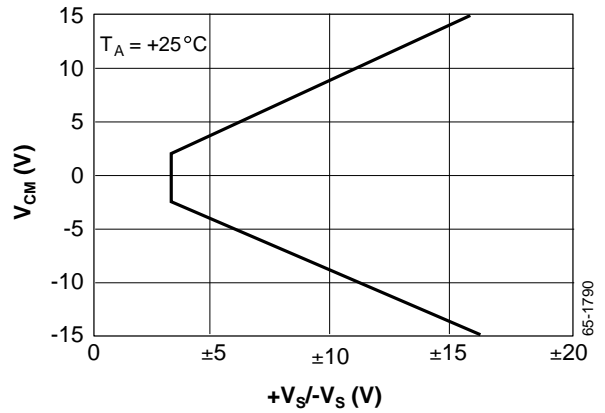

Figure 10. Common Mode Input Range vs. Supply Voltage

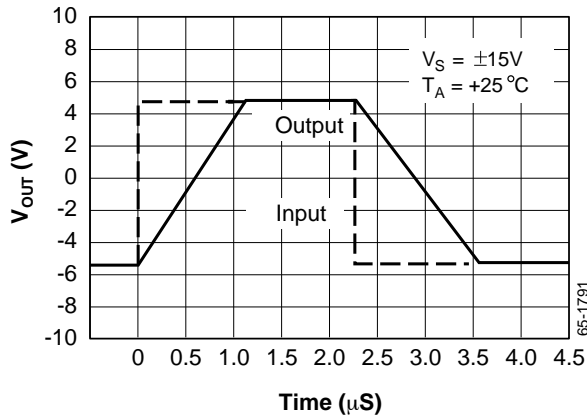

Figure 11. Follower Large Signal Pulse Response

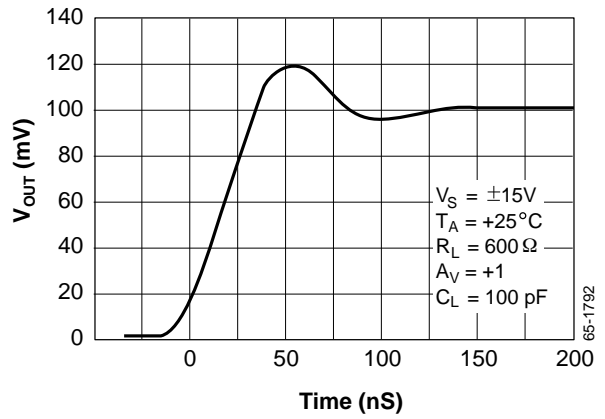

Figure 12. Transient Response Output Voltage vs. Time

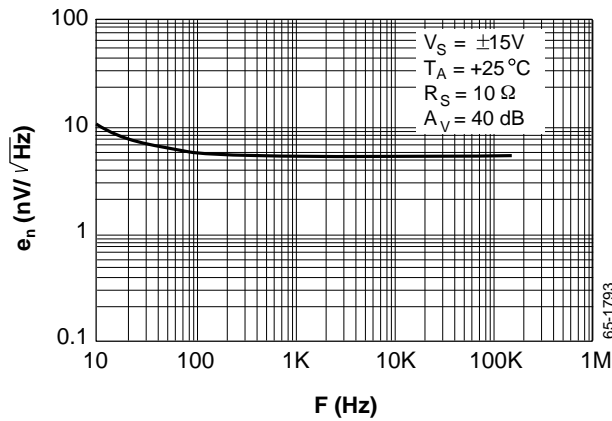
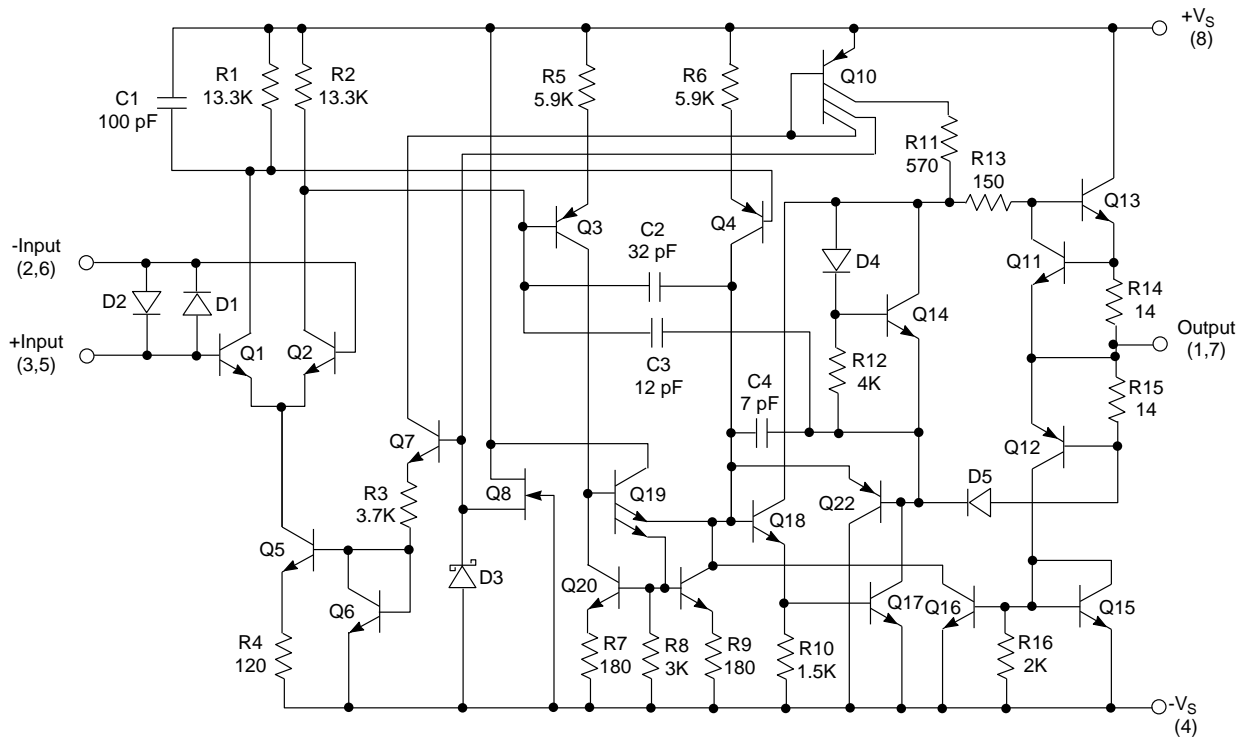

Figure 13. Input Noise Density vs. Frequency

Simplified Schematic Diagram (1/2 shown for 5532)



65-1780

Mechanical Dimensions

8-Lead Ceramic DIP Package

Symbol	Inches		Millimeters		Notes
	Min.	Max.	Min.	Max.	
A	—	.200	—	5.08	
b1	.014	.023	.36	.58	8
b2	.045	.065	1.14	1.65	2, 8
c1	.008	.015	.20	.38	8
D	—	.405	—	10.29	4
E	.220	.310	5.59	7.87	4
e	.100 BSC		2.54 BSC		5, 9
eA	.300 BSC		7.62 BSC		7
L	.125	.200	3.18	5.08	
Q	.015	.060	.38	1.52	3
s1	.005	—	.13	—	6
α	90°	105°	90°	105°	

Notes:

1. Index area: a notch or a pin one identification mark shall be located adjacent to pin one. The manufacturer's identification shall not be used as pin one identification mark.
2. The minimum limit for dimension "b2" may be .023 (.58mm) for leads number 1, 4, 5 and 8 only.
3. Dimension "Q" shall be measured from the seating plane to the base plane.
4. This dimension allows for off-center lid, meniscus and glass overrun.
5. The basic pin spacing is .100 (2.54mm) between centerlines. Each pin centerline shall be located within ± 0.010 (.25mm) of its exact longitudinal position relative to pins 1 and 8.
6. Applies to all four corners (leads number 1, 4, 5, and 8).
7. "eA" shall be measured at the center of the lead bends or at the centerline of the leads when " α " is 90°.
8. All leads – Increase maximum limit by .003 (.08mm) measured at the center of the flat, when lead finish applied.
9. Six spaces.

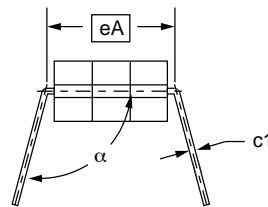
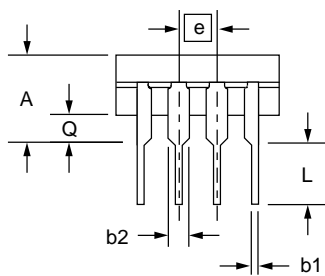
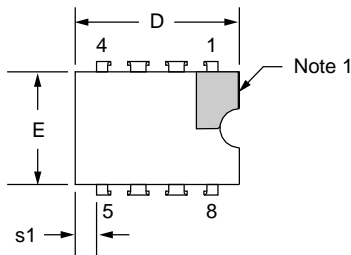

Mechanical Dimensions (continued)

8-Lead Plastic DIP Package

Symbol	Inches		Millimeters		Notes
	Min.	Max.	Min.	Max.	
A	—	.210	—	5.33	
A1	.015	—	.38	—	
A2	.115	.195	2.93	4.95	
B	.014	.022	.36	.56	
B1	.045	.070	1.14	1.78	
C	.008	.015	.20	.38	4
D	.348	.430	8.84	10.92	2
D1	.005	—	.13	—	
E	.300	.325	7.62	8.26	
E1	.240	.280	6.10	7.11	2
e	.100 BSC		2.54 BSC		
eB	—	.430	—	10.92	
L	.115	.160	2.92	4.06	
N	8°		8°		5

Notes:

1. Dimensioning and tolerancing per ANSI Y14.5M-1982.
2. "D" and "E1" do not include mold flashing. Mold flash or protrusions shall not exceed .010 inch (0.25mm).
3. Terminal numbers are for reference only.
4. "C" dimension does not include solder finish thickness.
5. Symbol "N" is the maximum number of terminals.

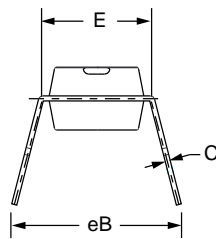
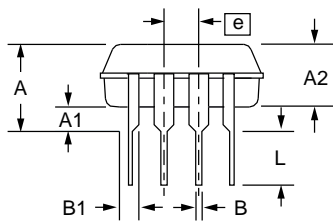
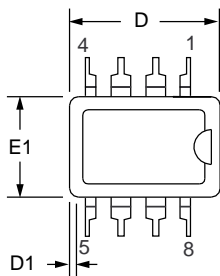

Mechanical Dimensions (continued)

8-Lead Metal Can IC Header Package

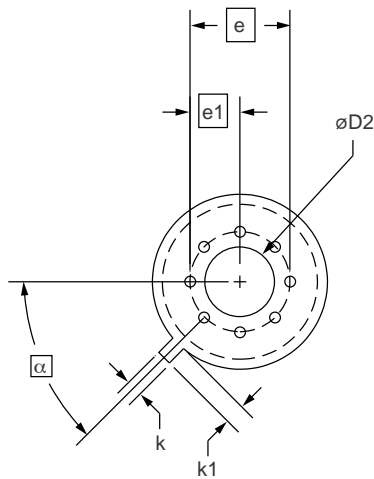
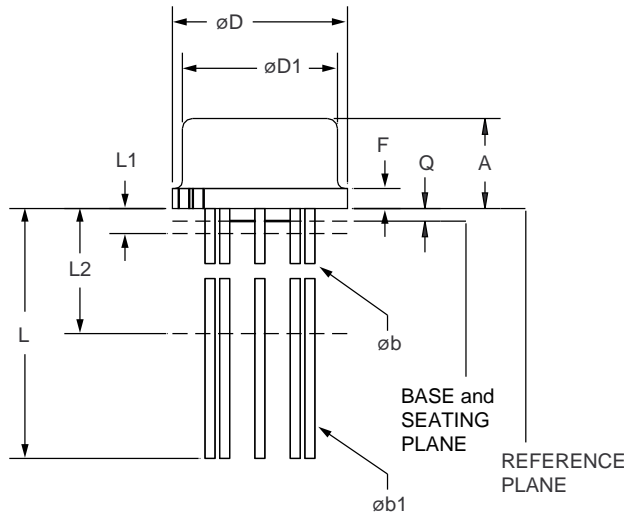

Symbol	Inches		Millimeters		Notes
	Min.	Max.	Min.	Max.	
A	.165	.185	4.19	4.70	
$\varnothing b$.016	.019	.41	.48	1, 5
$\varnothing b1$.016	.021	.41	.53	1, 5
$\varnothing D$.335	.375	8.51	9.52	
$\varnothing D1$.305	.335	7.75	8.51	
$\varnothing D2$.110	.160	2.79	4.06	
e	.200 BSC		5.08 BSC		
e1	.100 BSC		2.54 BSC		
F	—	.040	—	1.02	
k	.027	.034	.69	.86	
k1	.027	.045	.69	1.14	2
L	.500	.750	12.70	19.05	1
L1	—	.050	—	1.27	1
L2	.250	—	6.35	—	1
Q	.010	.045	.25	1.14	
α	45° BSC		45° BSC		

Notes:

1. (All leads) $\varnothing b$ applies between L1 & L2. $\varnothing b1$ applies between L2 & .500 (12.70mm) from the reference plane. Diameter is uncontrolled in L1 & beyond .500 (12.70mm) from the reference plane.
2. Measured from the maximum diameter of the product.
3. Leads having a maximum diameter .019 (.48mm) measured in gauging plane, .054 (1.37mm) +.001 (.03mm) -.000 (.00mm) below the reference plane of the product shall be within .007 (.18mm) of their true position relative to a maximum width tab.
4. The product may be measured by direct methods or by gauge.
5. All leads – increase maximum limit by .003 (.08mm) when lead finish is applied.

Ordering Information

Product Number	Temperature Range	Screening	Package
RC5532D/RC5532AD	0°C to +70°C	Commercial	8 Pin Ceramic DIP
RC5532N/RC5532AN	0°C to +70°C	Commercial	8 Pin Plastic DIP
RM5532D/RM5532AD	-55°C to +125°C	Commercial	8 Pin Ceramic DIP
RM5532D/883B	-55°C to +125°C	Military	8 Pin Ceramic DIP
RM5532AD/883B	-55°C to +125°C	Military	8 Pin Ceramic DIP
RM5532T/RM5532AT	-55°C to +125°C	Commercial	8 Pin TO-99 Metal Can
RM5532T/883B	-55°C to +125°C	Military	8 Pin TO-99 Metal Can
RM5532AT/883B	-55°C to +125°C	Military	8 Pin TO-99 Metal Can

Note:

1. /883B suffix denotes MIL-STD-883, Par. 1.2.1 compliant device.

The information contained in this data sheet has been carefully compiled; however, it shall not by implication or otherwise become part of the terms and conditions of any subsequent sale. Raytheon's liability shall be determined solely by its standard terms and conditions of sale. No representation as to application or use or that the circuits are either licensed or free from patent infringement is intended or implied. Raytheon reserves the right to change the circuitry and any other data at any time without notice and assumes no liability for errors.

LIFE SUPPORT POLICY:

Raytheon's products are not designed for use in life support applications, wherein a failure or malfunction of the component can reasonably be expected to result in personal injury. The user of Raytheon components in life support applications assumes all risk of such use and indemnifies Raytheon Company against all damages.

Raytheon Electronics
 Semiconductor Division
 350 Ellis Street
 Mountain View CA 94043
 415 968 9211
 FAX 415 966 7742